



Lumirror®

Polyester Film

I. Introduction

HANDLING MANUAL

1. Outline

This manual outlines the correct handling process for Toray's LUMIRROR Polyester (PET) film.

2. Packed for Safety During Transportation

Toray has carefully packed LUMIRROR to ensure that it is not damaged under normal transportation conditions. Toray provides sufficient shoring for its cargo during loading into container. This is to prevent the cargo from shifting during transit. If any of the following problems arise due to abnormal transportation condition, please refuse delivery and notify Toray or its local representatives as soon as possible. (When notifying Toray of such problems, please include photos of the damaged products together with the roll numbers written on the boxes.)

Problems due to abnormal transportation conditions

- 1) Cargo has shifted from its correct position.
- 2) Cardboard boxes are broken, crushed, or otherwise damaged.

Claims will be fully investigated and compensation made where appropriate. The quality of film made by Toray Industries, Inc. is guaranteed for 6 months after delivery.

I. 前言

1 °提纲

此手册提供东丽 Lumirror 薄膜正确处理方式 °

2 °供运输的安全包装

东丽为 Lumirror 提供安全包装以减低运输时可能造成的破坏 °当货物装入货柜时，东丽提供足够的锁定物，以防止货物移动 °如发丝现以下任何异常运输现象，请拒绝收货及马上通知东丽或当地代表公司 °（在通知东丽有关问题时，请附上该损坏货物之相片及薄膜卷品号）

异常运输现象

- 1) 货物已移位
- 2) 纸箱破裂，压扁或损坏

东丽将严格调查，并在需要时提供适当的赔偿 °东丽货物保限期为运输期后六个月 °

II. Delivery of LUMIRROR to Customers' Warehouse

1. Packing of LUMIRROR

LUMIRROR rolls are supported at both ends by plywood, which is bigger than the roll diameter. They are then placed in cartons wrapped with tubular polyethylene film. With this packing system, the rolls are self-suspended. This prevents the surfaces of the rolls from coming in contact with the cartons (Fig. 1). Rolls in the cartons are usually delivered in pallets. Customer may request for wooden crates.

II. Lumirror 包装及运输

1 °Lumirror 包装

Lumirror 是以大过薄膜直径的胶合板支撑 °以管状形 LDPE 袋包装的薄膜卷过后将被置入纸箱 °此包装系统有助于薄膜卷定型作用，并阻止其表面触及纸箱（图案一） °视客户需求，薄膜卷通常以板床或木条箱运送 °

Fig. 1. LUMIRROR Packing 图案一 °Lumirror 包装

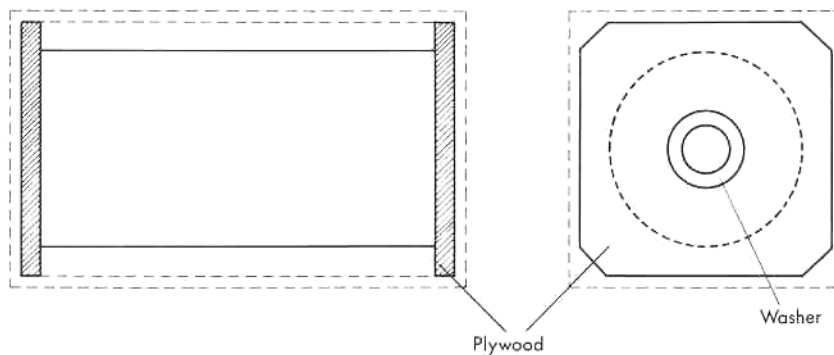

2. Unloading Precautions

When pallets or wooden boxes are unloaded from goods-trains or trucks, it is very important to keep the rolls horizontally and not to drop them or jolt them in any way. If rolls are jolted, it may result in unexpected defects such as wrinkles, marks on the film or paper core damage, which will be observed after unpacking.

2 °卸货须知

卸货时，须确定薄膜卷与地平线平行，以避免货物跌落或震动，或薄膜卷呈皱纹及轴心损坏 °

III. Storage Condition of LUMIRROR

1. Recommended Storage Conditions

As film is extremely sensitive to temperature and humidity conditions, it is necessary to avoid exposing the film to extremes of temperature and humidity during storage.

Recommended storage conditions are as follows:

Temperature : 15 to 35 °C (59 to 95 °F)

Humidity : 50 to 80% RH

Surface wrinkles and other roll defects can be caused by storage outside of these recommended ranges.

2. Change of Storage Conditions

A sudden change in storage conditions can cause surface wrinkles on the rolls. To protect rolls from these undesirable wrinkles, we recommend the following storage condition prior to processing (Table 1).

Table 1. Recommended Storage Conditions

	Case A	Case B
Original storage conditions	Below 6 °C (below 43 °F)	7 to 14 °C (45 to 55 °F)
Recommended procedure before processing	Keep rolls at 7 to 14 °C (45 to 55 °F) for 24 hours before processing, then proceed as described in Case B	1. Special procedure are unnecessary provided humidity is less than 80% RH. 2. In case the humidity is more than 81% RH, the rolls are to be kept at 15 to 30 °C (59 to 86 °F) for 8 hours.

III. Lumirror 储存环境

1 °储存环境建议

由于薄膜对温度及湿度敏感，必须避免将货物储存于曝晒及潮湿的地方 °

储存环境建议如下：

温度：摄氏 15 至 35 度(华氏 59 至 95 度)

湿度：50 至 80%RH

此储存建议外之环境可导致薄膜卷表面呈皱纹及其他损坏 °

2 °储存环境建议

忽然的环境变换可导致薄膜卷表面呈皱纹 °为防止该问题，东丽建议以下货物处理前储存环境（图表

一） °

图表一 °忽然的环境变换措施

	例子甲	例子乙
原定储存环境	摄氏 6 度以下 (华氏 40 度以下)	摄氏 7 至 14 度 (华氏 45 至 55 度)
处理前防范建议	将薄膜卷储存于 摄氏 7 至 14 度 (华氏 45 至 55 度) 环境下长达 24 小时， 然后再进行例子乙	1 °如 RH 少过 80%，无需特别措施 2 °如 RH 多过 81%，将薄膜卷储存 8 小时，于摄氏 15 至 30 度 (华氏 59 至 86 度)

3. Storing Rolls

When rolls of LUMIRROR are to be stored, they should remain as they are received, that is, in the original cartons and on the pallets.

If it is not possible to store rolls as received, it is necessary to pay special attention to the following (Fig. 2):

- 1) When de-palletizing, rolls should always be kept horizontal.
- 2) The same applies during transportation of cartons (i.e. they should not be rolled over).

3 °薄膜卷储存

储藏 Lumirror 时，薄膜卷须原封不动储藏于纸箱盒，并置于板床上 °

如须改变包装，请注意以下重点（图案二）：

- 1) 拆除后，薄膜卷须保持地平线位置
- 2) 此条例也应用于货物搬动（勿翻动货物）

Fig. 2. Not Recommended Rolls Transportation 图案二 °错误搬运法

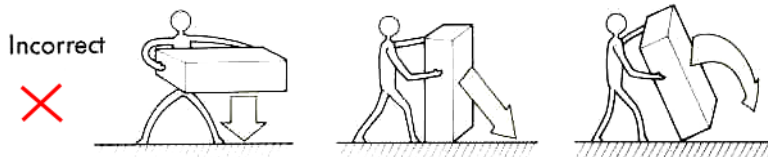

- 3) In order to avoid the above problems, please make sure cartons are not stacked crosswise (Fig. 3).
- 3) 如欲防止以上问题，请确保纸箱盒勿置于交叉方向 °

Fig. 3. Incorrect Stacking 图案三 °错误叠法

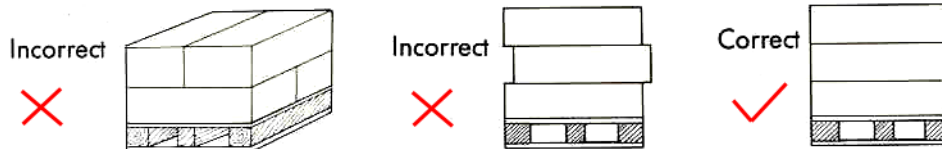

- 4) When stacking cartons of a different size from the ones underneath, flat wooden boards should be placed between the two (Fig. 4).
- 4) 当堆叠不同形状的纸箱时，须置木板于其中 °（图案四）

Fig. 4. Carton Stacking 图案四 °纸箱叠法

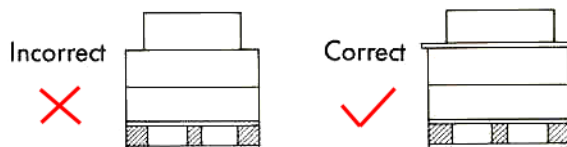

- 5) The height of the stacked cartons should be limited to 170cm for greater safety and working efficiency.
- 5) 为安全及工作效率起见，堆叠高度应限于 170 公分 °

IV. Unpacking of LUMIRROR

IV °LUMIRROR 包装拆除法

2. Unpacking Method for Wooden Crates 木条箱拆除法

1) Remove the nails that hold the wooden crate and the pallet together.

1) 将钉子从木条箱及板床的衔合处除去 °

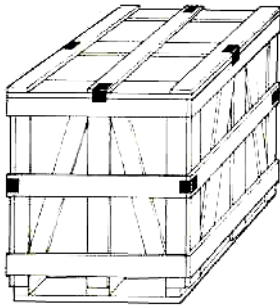

2) Lift the wooden crate upwards.

2) 小心将木条箱往上拉 °

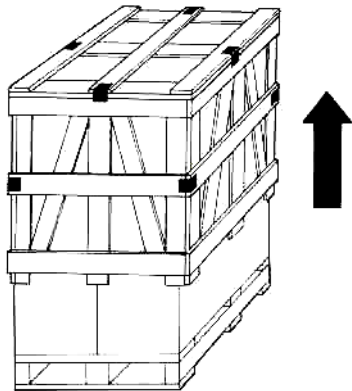

3) Set aside the wooden crate, leaving the cartons on the pallet.

3) 将木条箱置一旁，纸箱平放于板床 °

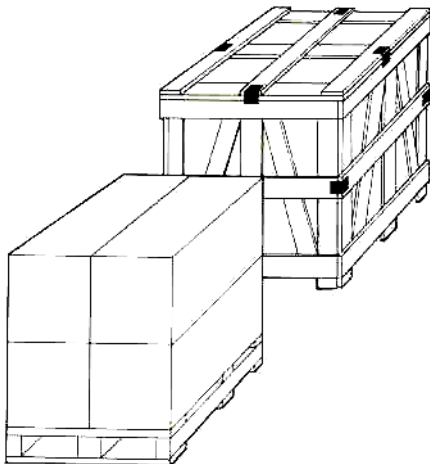

Unpacking Method for Cartons 纸箱拆除法

Three types of cartons are used for packing LUMIRROR: side-open style (A), top-open style (A-4), and cover box style (C).

Unpacking of side-open cartons

- 1) Cut the adhesive tape which seals both ends of the carton with a razor or knife.
- 2) Then cut the cartons horizontally to expose the full rolls.

侧开

- 1) 剪断纸箱两旁胶带 °
- 2) 应用平行线切除法剪开纸箱，呈开薄膜卷 °

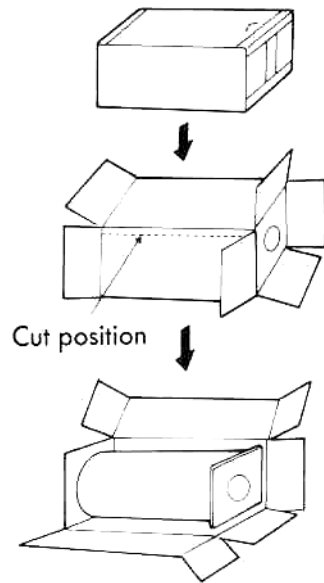

Unpacking of top-open cartons

- 1) Cut the adhesive tape, which seals the top 4 edges of the carton.
- 2) Then cut the cartons horizontally to expose the full rolls.

顶开

- 1) 剪断纸箱表层胶带 °
- 2) 应用平行线切除法剪开纸箱，呈开薄膜卷 °

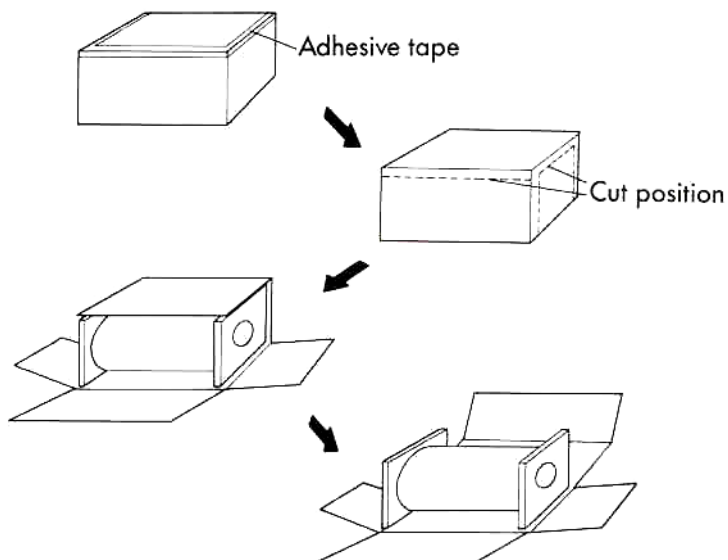

Unpacking of cover box cartons

- 1) Remove the upper cover box.
- 2) Pull out the ends of the Polyethylene tube.
- 3) Insert a rod through the core and lift the roll.

箱罩

- 1) 移开箱罩 °
- 2) 将箱内 LDPE 袋拉开 °
- 3) 用圆棒穿越卷心，以支撑薄膜卷 °

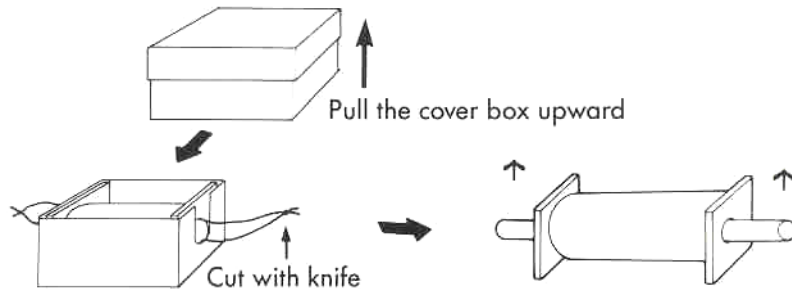

Temporarily laying down the rolls 薄膜卷暂置法

Lay the roll down on a support covered with soft material or hang the roll on a stand using the supporter inside the core of the roll.

将薄膜卷平躺于软性支撑物，或用圆棒穿越卷心，以固定物支撑薄膜卷 °

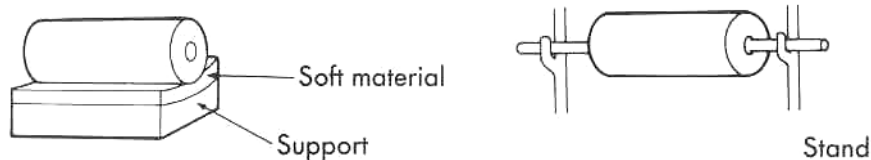

TORAY

For further inquiry: -

Toray Industries, Inc. - Film Trading Department

Toray Bldg., 2-1, Nihonbashi-Muromachi 2-chome, Chuo-ku, Tokyo 103-8666, Japan Tel.: (81) 03-3245-5566 Fax: (81) 03-3245-5867

Penang Penfibre Sdn Bhd - Film Division Lot 128-130, Prai FIZ 1, 13600 Penang, Malaysia. Tel.: (6) 04-3846121 Fax: (6) 04-3977913

Singapore Toray Industries (Singapore) Pte. Ltd. 31C, Exeter Road #03-01, Comcentre 3 Atrium, Singapore 293734 Tel.: (65)734-7064 Fax: (65)533-2215

Bangkok Toray International (Thailand) Ltd. 11th Floor, Buhajit Building, 20 North Sathorn Road, Bangrak, Bangkok 10500, Thailand. Tel.: (662) 236-3529 Fax: (662) 266-6608

Jakarta P.T. Toray Trading Indonesia (P.T. TRI) 3rd Floor, Summitas II, 61-62, Jl. Jenderal Sudirman, P.O. Box. 6912/JKSST JKT 12069, Indonesia. Tel.: 5201756 Fax: 5201294

Shanghai Toray Trading (Shanghai) Co., Ltd. 10th Floor, HSBC TOWER, 101 Yin Cheng East Road, Pudong New Area, Shanghai, 200120, China. Tel.: (86-21) 6841-4632 Fax: (86-21) 6841-3220

Hong Kong Toray Industries (HK) 14th Floor, TAL Building, 49 Austin Road, Kowloon, Hong Kong. Tel.: 2196-7000 Fax: 2196-7138

Taipei Tong Shing Inc. 6th Floor, No. 123 Nanking Rd., Sec. 2, Taipei T 104. Tel.: 886 (2) 2506-0700 Fax: 886 (2) 2508-0662

Rhode Island Toray Plastics (America), Inc. 50 Belver Avenue, North Kingstown, RI 02852, U.S.A. Tel.: (1) 401-294-4511 Fax: (1) 401-294-2154

Frankfurt Toray Deutschland GmbH Hugenottenallee 175, 63263 Neu-Isenburg, Germany Tel.: (49-6102)79990 Fax: (49-6102)7999291

LUMIRROR is a registered trademark of Toray Industries, Inc.